

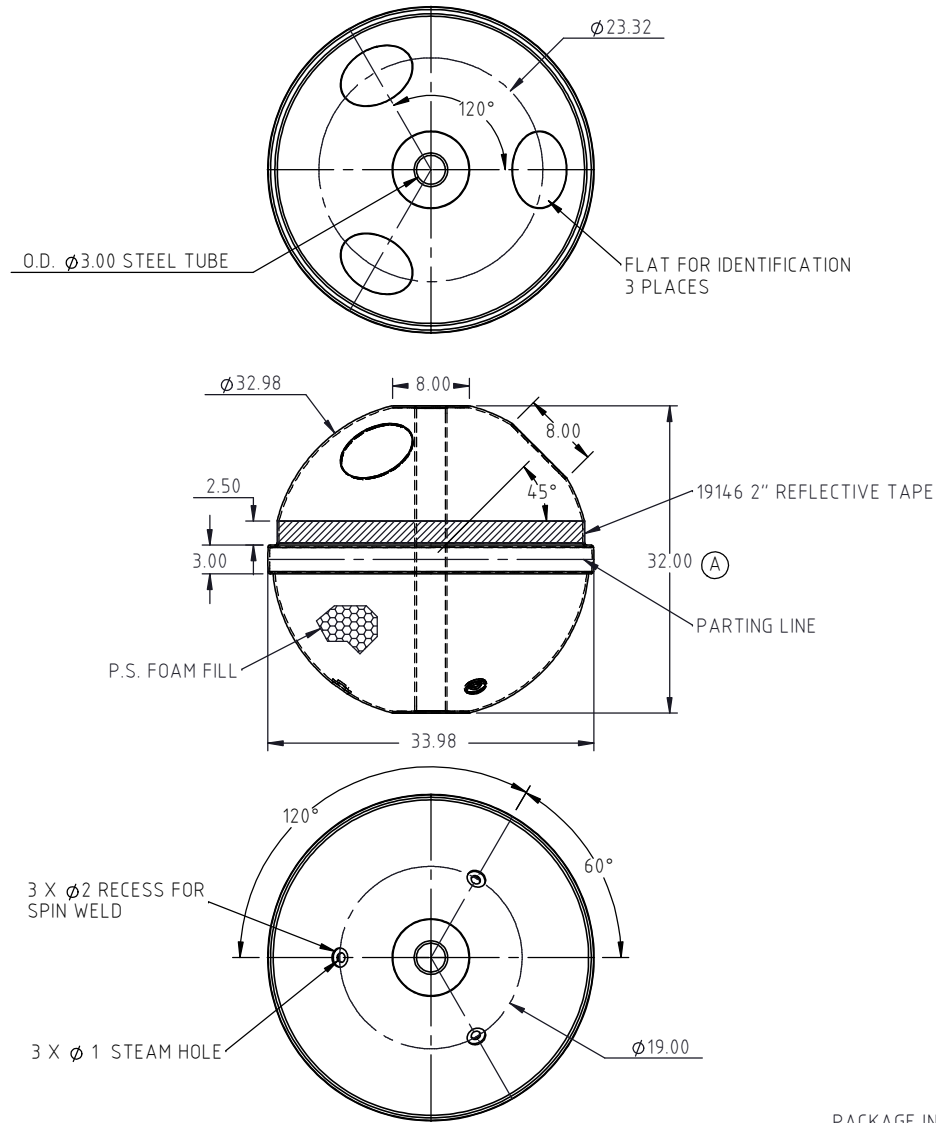
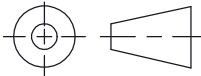

Copyright. All information furnished within this document, electronic file or design correspondence is the property of Den Hartog industries, Inc. and shall not be used, disclosed to others or copied without the expressed written consent of Den Hartog Industries, Inc.



PACKAGE IN 19147 CARTON

				DRAWN / DATE ADH 7/20/10		MATERIAL 10948		 <p>Den Hartog INDUSTRIES, INC.</p> <p>Ace Roto-Mold Injection Molding Blow Molding Sowjoy</p> <p>4010 HOSPERS DRIVE S. BOX 425, HOSPERS, IOWA 51238-0425</p>
A	32" WAS 29.95"	ADH 1/9/13	2557	APPROD. / DATE REH 10/26/10				
REV	DESCRIPTION	BY / DATE	CCN					
ALL DIMENSIONS ARE IN DECIMAL INCHES TOLERANCES UNLESS OTHERWISE SPECIFIED		THIRD ANGLE PROJECTION ANSI 14.5M		SHOT WEIGHT: 26.0 LBS		NOTES: 1.) .200 WALL 2.) 9.4 LBS FOAM		DESCRIPTION 32 INCH FOAM FILLED MORING BUOY
POLYETHYLENE ±1% @ 68°F		METAL DECIMAL ± .125" FRACTION ± 1/4" ANGLE ± 1°		SHIPPING WEIGHT: 49.0 LBS		FINISH:		SCALE N.S.
								PART NO. FFMB-3232