

PROPRIETARY DATA

INFORMATION FURNISHED HEREIN IS THE PROPERTY OF DEN HARTOG INDUSTRIES INC. AND SHALL NOT BE USED, DISCLOSED TO OTHERS, OR COPIED WITHOUT EXPRESSED WRITTEN CONSENT OF DEN HARTOG IND. ALL RIGHTS RESERVED.

(B)

FFMB-32FRND

(B)

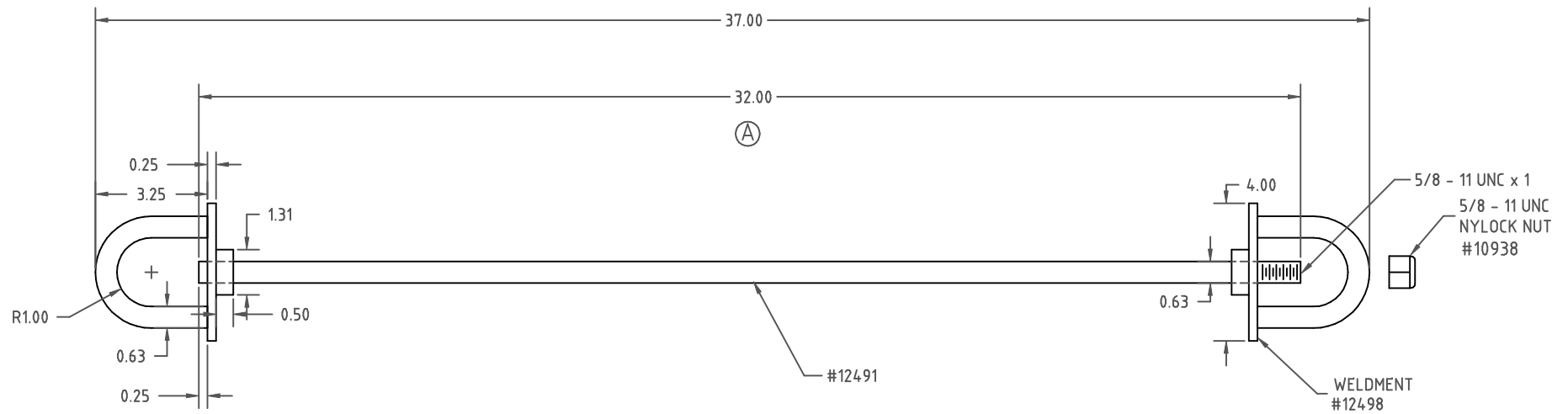

				DRAWN /DATE DHJ 10/17/07	MATERIAL
B	CHANGED P.N.	10/27/10 REH	2106		MILD STEEL GALVANIZED FINISH
A	ADD TO LENGTH WAS 31.75	6/11/09 DHJ		APPRD. /DATE REH 2/19/09	
REV	DESCRIPTION	DATE	APPRD.	CCN	
ALL DIMENSIONS ARE IN DECIMAL INCHES TOLERANCES UNLESS OTHERWISE SPECIFIED				THIRD ANGLE PROJECTION ANSI 14.5M	NOTES:
± .062					



Ace Roto-Mold
A DIVISION OF DEN HARTOG INDUSTRIES, INC.
4010 HOSPERS DRIVE S., BOX 425, HOSPERS, IOWA 51238

CLIENT / DESCRIPTION	
MOORING BUOY HARDWARE 32" FIXED	
SCALE NONE	PART NO. FFMB-32FRND