

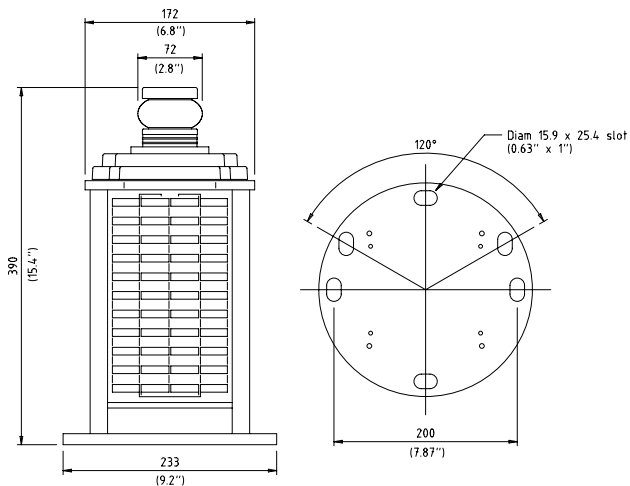

**BargeSafe™ Solar 3nm**  
**LED Barge Light**  
**Installation & Service Manual**

# BargeSafe™ Solar 3nm LED Barge Light

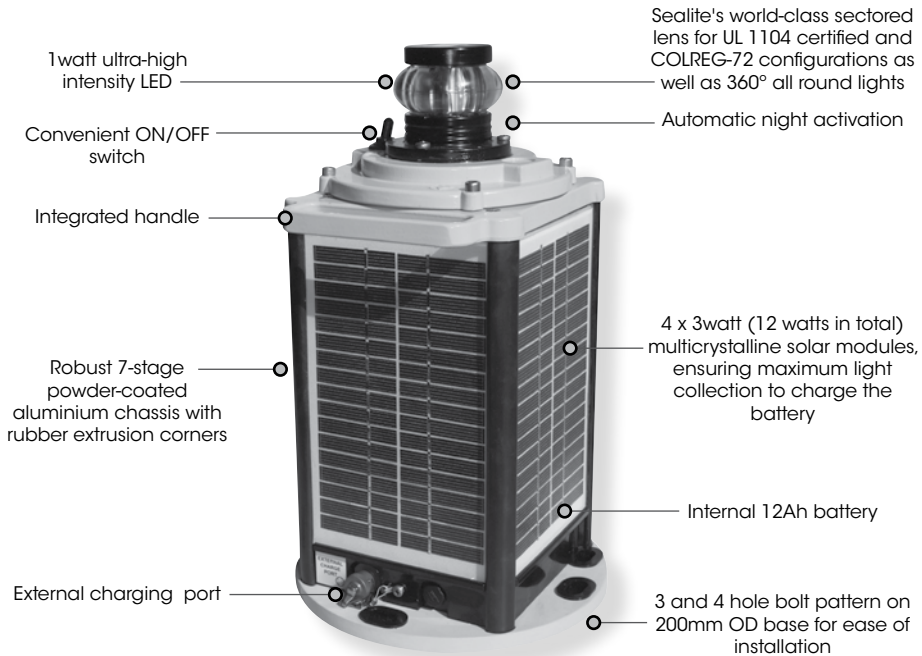

## Table of Contents

<b>Introduction</b> .....	Page 4
<b>Operating Principle</b> .....	Page 4
<b>Technology</b> .....	Page 4
<b>BargeSafe™ Solar 3nm Model</b> .....	Page 5
<b>Application</b> .....	Page 6
<b>Installation</b> .....	Page 7
<b>Maintenance and Servicing</b> .....	Page 9
Replacing the Battery .....	Page 9
Long Term Battery Storage .....	Page 9
How to Change the Regulator .....	Page 10
Solar Panel Replacement.....	Page 11
<b>Trouble Shooting</b> .....	Page 12
<b>Sealite LED Light Warranty</b> .....	Page 14

Version No.	Description	Date	Approved
1.0	Launch Catalogue	Feb 2010	A. Dixon
1.1	Logo, Warranty and Maintenance Update	July 2010	M. Henry
1.2	Update: Spec Table	May 2012	J. Dore
1.3	Update: Spec Table	May 2012	K. Paton

## Introduction

**Congratulations! By choosing a Sealite BargeSafe™ Solar you are the owner of one of the most advanced LED marine lights available.**

Sealite Pty Ltd has been manufacturing lights for over 25 years, and particular care has been taken to ensure your light gives years of service.

The Sealite BargeSafe™ Solar 3nm complies with requirements for a 3 mile light under international standard UL 1104, Marine Navigation Lights, and US Coast Guard COLREG-72, and has been tested and certified to the relevant sections by Independent Testing Laboratories Inc. Boulder, CO, in 2008.

A Sealite Warranty Registration Card accompanies your light and must be returned to validate your warranty.

## Operating Principle

The BargeSafe™ Solar 3nm barge lights use the latest advancements in LED (Light Emitting Diode) technology as a light source. As a user, you can expect in excess of 100,000 hours of LED operation, with minimal power consumption.

The light head is powered by a 12V 12Ah SLA Battery which is recharged during the day using 4 x 3watt solar panels. This combination means the light is able to recharge with limited exposure to sun. The solar panels of the light convert sunlight to an electrical current that is used to charge the battery. The battery provides power to operate the light at night. The flasher unit has very low current requirements. A microprocessor drives an ultra bright LED through a DC/DC converter, which enables the LED to operate within the manufacturer's specifications. The battery is protected from over-charging within the circuit to ensure maximum battery life. The BargeSafe™ Solar 3nm Light utilises a small microprocessor to control the LED function and monitor the light levels to enable the light to turn on automatically at night. During the day, the BargeSafe™ Solar 3nm Light runs a number of self diagnostic functions.

## Technology

***Sealite is the world's fastest growing manufacturer of marine aids to navigation. We employ leading mechanical, optical, hardware & software engineers to create innovative products to service the needs of our customers worldwide, and offer the widest range of solar-powered LED lanterns in the marketplace.***

### Electronics

Sealite employs leading in-house electronic engineers in the design and development of software and related circuitry. All individual electronic components are sourced directly by Sealite procurement staff ensuring that only the highest quality components are used in our products.

### LED Technology

All marine lanterns use the latest advancements in LED (Light Emitting Diode) technology as a light source. The major advantage of LED's over traditional light sources is well established in that they typically have an operational life in excess of 100,000 hours, resulting in substantial savings to maintenance and servicing costs.

### Precision Construction

Commitment to investing in the design and construction of injection-moulded parts including optic lenses, light bases and a range of other components ensures that all Sealite products are of a consistent & superior quality.

### Optical Performance

Sealite manufactures a range of marine LED lenses moulded from multi-cavity dies. Complex shapes such as the SL70, BargeSafe™ and 16-segment multi-focus lenses are a testament to the company's superior in-house lens manufacturing capabilities and outstanding optical performance.

### Award-winning, Patented Technology

Several United States and Australian patent registrations are held on Sealite's range of innovative designs, with other regional patents pending in Canada, United Kingdom and Europe.

# BargeSafe™ Solar 3nm Model

*The Sealite BargeSafe™ Solar 3nm LED barge lights are certified to UL 1104 and COLREG-72 with >3nm visible range.*

*The LED barge light is one of the most advanced in its class, and incorporates a host of innovative features designed to make the unit extremely user-friendly.*

*The world-class LED lens is designed by Sealite and achieves precise intensity and sectoring requirements from a single LED light source. This design helps achieve a lower operational current compared with alternate LED barge lights.*

## SPECIFICATIONS •

### Light Characteristics

Light Source  
Available Colours  
Maximum Available Intensity (cd)†  
Visible Range (nm)  
Horizontal Output (degrees)

1 x 1 watt ultra-high intensity LED (sectored configuration).  
Red, Green, White, Yellow as per UL 1104 & COLREG-72  
As per UL 1104 & COLREG-72  
>3nm as per UL 1104 & COLREG-72  
Red - 112.5° Green - 112.5° White - 135° Yellow - 225° as per UL 1104 & COLREG-72.

Flash Characteristics  
LED Life Expectancy (hours)

As per UL 1104 & COLREG-72 (steady-on & flashing)  
>100,000

### Electrical Characteristics

Current Draw (mA)  
Circuit Protection  
Nominal Voltage (V)  
Temperature Range

Minimal  
Integrated  
12  
-40 to 80°C

### Solar Characteristics

Solar Module Type  
Output (watts)  
Solar Module Efficiency (%)  
Charging Regulation

Multicrystalline  
12 (4 x 3watt)  
14  
Microprocessor controlled

### Power Supply

Battery Type  
Battery Capacity (Ah)  
Nominal Voltage (V)  
Autonomy (days)  
Battery Service Life

SLA (Sealed Lead Acid)  
12  
12  
>24  
Average 5 years

### Physical Characteristics

Battery Housing

7-stage powder-coated aluminium chassis with UV-stabilised rubber corners & gaskets

Lens Material  
Lens Mount & Top  
Lens Design

Acrylic  
Anodised aluminium  
Internal single LED cavity with individual sectoring compartments to meet all UL 1104 & COLREG-72 angles for light output. Internal 3 x LED cavities to suit 360° all round light configuration  
3 & 4 holebolt pattern on 200mm OD base

Mounting  
Height (mm/inches)  
Width (mm/inches)  
Mass (kg/lbs)  
Product Life Expectancy

390 / 15<sup>2</sup>/<sub>5</sub>  
233 / 9<sup>1</sup>/<sub>5</sub>  
9.2 / 20<sup>1</sup>/<sub>4</sub>  
Up to 12 years

### Certifications

Approvals  
Quality Assurance  
Waterproof

UL 1104, COLREG-72  
ISO9001:2008  
IP67

### Intellectual Property

Trademarks

SEALITE® is a registered trademark of Sealite Pty Ltd  
BargeSafe™ is a trademark of Sealite Pty Ltd

### Warranty \*

1 year

• Specifications subject to change or variation without notice  
\* Subject to standard terms and conditions  
† Intensity setting subject to solar availability



## Application

Please check with your local authority before installing the Sealite BargeSafe™ Solar 3nm lantern to ensure the position and range is appropriate for your requirements.

- The Stern (White) Barge light provides an angle of 135°.
- The Port (Red) Barge lights provide an angle of 112.5°.
- The Starboard (Green) Barge lights provide an angle of 112.5°.
- The Flashing (Yellow) Barge light provides an angle of 225°.
- 360° Steady Anchor Light

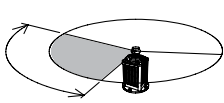

GREEN (112.5°)

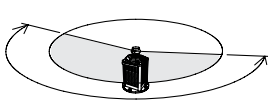

YELLOW (225°)

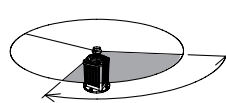

RED (112.5°)

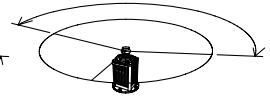

WHITE (135°)

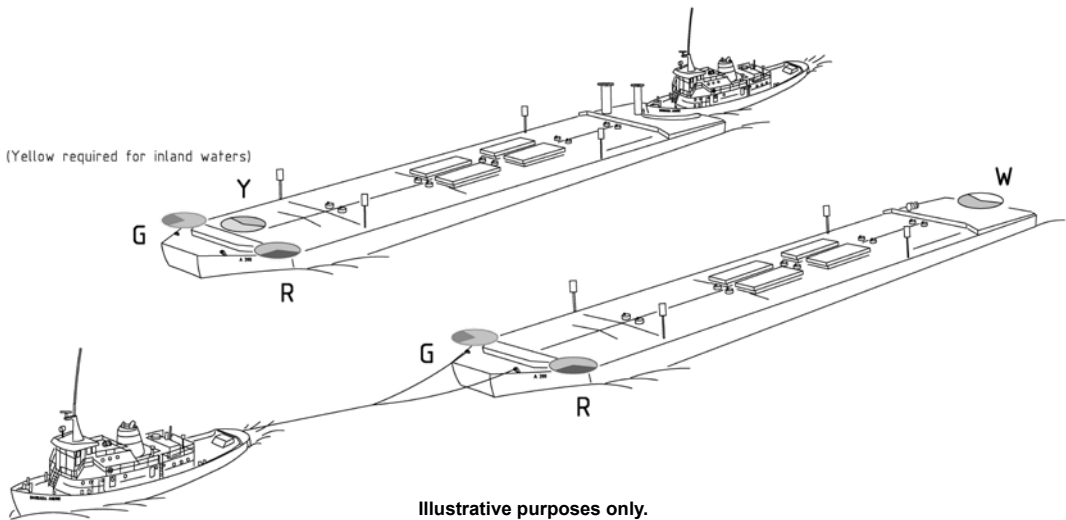

## Installation

- Remove the BargeSafe™ Solar 3nm Light from the box and remove all protective packaging.
- Switch the BargeSafe™ Solar 3nm Light on using the ON/OFF switch next to the Light Head.
- The light will activate for 30 seconds. It will automatically switch off after exposure to 30 seconds of daylight.
- Position the light so it is directed correctly in accordance with local shipping regulations. See previous page for suggested locations.
- Secure the BargeSafe™ Solar 3nm Light to the barge,
- Cover with a dark jacket to make sure the light activates during darkness. The BargeSafe™ Solar 3nm Light needs to be exposed to darkness for at least 30 continuous seconds before it will activate.

### Peep Light

The Yellow Masthead BargeSafe™ Solar 3nm can be fitted with a Peep Light to help operators.

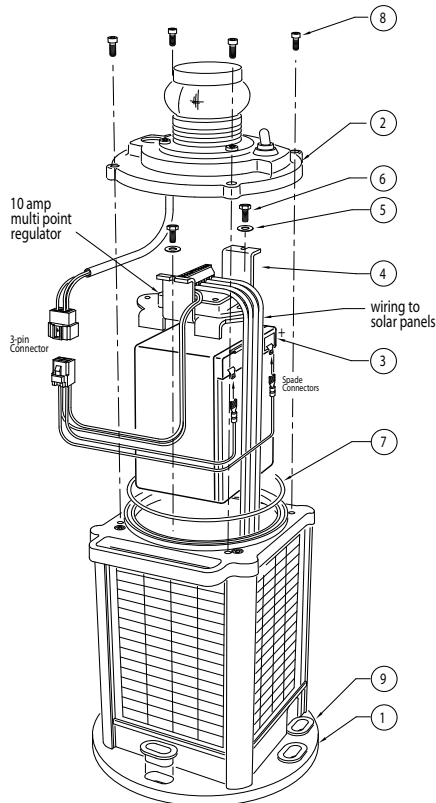

Item	Description	Quantity
1	Base	1
2	BLSX Lens Assembly	1
3	Battery 12v 12Ah	1
4	Battery Clamp	1
5	Washer M5	2
6	M4 Cap Screw	2
7	O-Ring, Ø145 x 4.0	1
8	Socket Head Screw M6 x 16	4
9	Protective Sleeve for Base	6

Fig 2. BargeSafe™ Solar 3nm Barge Light components



### **Testing the BargeSafe™ Solar 3nm Light**

1. Turn the BargeSafe™ Solar 3nm on by flicking the switch on the lid.  
*The light will automatically activate for 30 seconds. If the BargeSafe™ Solar 3nm is in daylight, it will automatically turn off.*
2. Place the light in darkness for approximately 1 minute. *E.g. a dark room or cover over the light with a dark jacket. The BargeSafe™ Solar 3nm needs to see 30 seconds of continuous darkness before it will activate.*
3. If the light does not activate within this time, check the following.
  - Is the light is turned on?
  - Is the battery correctly installed?
  - Is it dark enough?

### **Low Battery Status**

The BargeSafe™ Solar 3nm will run for many nights on a single 12v 12Ah SLA Battery, as a number of battery brands may be used in this unit, the number of nights the BargeSafe™ Solar 3nm will operate for will vary.

The BargeSafe™ Solar 3nm will start to flash once every 10 seconds when the battery voltage drops below 10.5V

The BargeSafe™ Solar 3nm will stop operating when the battery drops below 10.5V.





## Maintenance and Servicing

Designed to be maintenance free, the BargeSafe™ Solar 3nm requires minimal attention, though the following maintenance and servicing information is provided to help ensure the life of your Sealite product.

1. Cleaning Solar Panels - occasional cleaning of the solar panels may be required. Using a cloth and warm soapy water, wipe off any foreign matter before rinsing the panels with fresh water.
2. Battery Check - inspection of batteries should be performed every three years (minimum) to ensure that the charger, battery and ancillary electronics are functioning correctly. Using a voltage meter, check that the battery voltage is at least 12 volts under 100MA load, and ensure all terminals are clear of foreign matter.

### Replacing the battery

The has an internal battery compartment which provides the user with the ability to change the battery after years of operation (see figure 2).

1. Remove the four socket-head screws on the top lens assembly and open.
2. Disconnect the positive and negative wires from the battery.
3. Remove battery retaining plate and lift battery from cradle.
4. Discard old battery in a safe manner.
5. Reattach positive and negative wires to the new battery.
6. Replace the battery into the cradle, and re-affix retaining plate with two wing-nuts and washers.
7. Replace the lens assembly back onto lantern housing ensuring that no wiring is protruding, and screw four socket cap screws firmly. Ensure the o-ring seal is clean and clear from foreign matter.
8. To test place dark cover (towel or jacket) on top of light to activate sensor, light will come on.

***Care must be taken to observe the polarity of each wire before they are connected. To ensure waterproofing of the unit, make sure that no wires are protruding and that there is an even seal. Always discard old batteries in a safe manner.***

### Long Term Battery Storage

If the BargeSafe™ Solar 3nm is to be placed in storage for an extended period please follow the below information.

The sealed lead acid batteries inside the lights must always be stored in a fully charged state.

Always make sure the ON/OFF switch is in the OFF position.

If an ON/OFF switch is not fitted please disconnect the light head from the solar unit.

All batteries will discharge over time and the rate of discharge is dependent on temperature.

If the light is being stored in temperatures greater than 40°C the battery will discharge faster.

Please check battery regularly and recharge if necessary,

Either

Re-connect the light head and battery and place unit in the sun for 2-4 days

**Or/**

Re-connect light head and battery and place in front of a halogen lamp for 1-3 days. ***(Do not place the halogen light too close to the solar panel or the panel may be overheated)***

### How to Change the Regulator

1. Remove the 4 x M6 x 20 socket head cap screws (SHCS) and 4 x M6 nylon washers, then disconnect the light head from the chassis.
2. Remove the 2 x M4 x 20 SHCS, 2 x M4 spring washers and 2 x M4 penny washers then remove the upper battery bracket containing the regulator.
3. Disconnect the battery.
4. Take note of the wire colours and location in the regulator.
5. Disconnect the wires from the regulator.
6. Remove the 2 x M4 CSSK screws, 2 x M4 nylock nuts and 2 x M4 penny washers that retain the regulator to the top battery bracket and remove the regulator.
7. Fit the new regulator using the 2 x M4 CSSK screws, 2 x M4 penny washers and 2 x M4 nylock nuts.
8. Connect the solar positive wires to the solar + points on the regulator.
9. Connect the solar negative wires to the solar – points on the regulator.
10. Connect the battery positive wires to the Battery + point on the regulator.
11. Connect the battery negative wire to the battery – point on the regulator.
12. Reconnect the battery.
13. Refit the battery top bracket into the solar unit using the 2 x M4 x 20 SHCS.
14. Ensure the top O-ring is sitting correctly into the top casting. Refit the light head and tighten the M6 x 20 SHCS with the 4 x M6 nylon washers evenly. **DO NOT OVERTIGHTEN.**



Use the label to ensure correct location of wires during assembly



SL10 AMP Regulator shown when correctly fitted

### Solar Panel Replacement

The BargeSafe Solar 3nm is built around an internal aluminium chassis. The solar panels can be user-replaced in the unlikely event that one is broken or damaged during the product's life.

Follow the steps below or contact support@sealite.com for more details.

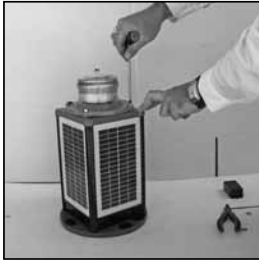

1. Remove 4 x M6 x 20 socket head cap screws (SHCS) and 4 x M6 nylon washers and disconnect the light head from the chassis
2. Remove the 2 x M4 x 20 socket head cap screws (SHCS), 2 x M4 spring washers and 2 x M4 penny washers. Remove the upper battery bracket containing regulator
3. Disconnect the battery



4. Remove 4 x M6-35mm long socket head cap screws, to remove the top casting from the chassis.

**Note:**

Be careful not to damage the o-rings on each of these screws. If replacements are required please use standard 6x1.0mm o-ring.



5. Slide the rubber corner out of the chassis, it may be necessary to lubricate the edges of the solar panels with grease or oil based lubricant if this is difficult to remove.
6. Unscrew the affected panel wires from the regulator and remove the solar panel from the chassis.

7. Clean any silicon off the chassis from the solar panel junction box hole and add a new seal to ensure the solar panel is watertight when assembled.

8. Repeat the process in the reverse order to replace a new panel.

**Note:**

Make sure the O-rings on the top casting and 4 x M6-35mm long socket head cap screws are coated in silicon grease before re-assembling.



**The replacement of a solar panel should only be performed by a confident technician.**  
*Sealite cannot guarantee the chassis will remain waterproof, if it not performed by Sealite staff.*  
*To test for any leaks remove the gore vent and pressurise the assembled Light to 1.5psi.*

## Trouble Shooting

Problem	Remedy
Lantern will not activate.	<ul style="list-style-type: none"> <li>• Ensure lantern is in darkness.</li> <li>• Wait at least 60 seconds for the program to initialise in darkness.</li> <li>• Ensure battery is properly connected.</li> <li>• Ensure battery has sufficient voltage.</li> </ul>
Lantern will not operate for the entire night.	<ul style="list-style-type: none"> <li>• Battery needs either recharging or replacement.</li> </ul>
Battery is corroding due to water in the compartment.	<ul style="list-style-type: none"> <li>• Check the rubber seal is fitted correctly. Make sure there are no cracks or holes in the seal. Make sure a silicone grease is used on the seal for added sealing.</li> </ul>
Lantern will not turn off	<ul style="list-style-type: none"> <li>• Ensure the light's lens is not covered with debris</li> </ul>
Light is flashing	<ul style="list-style-type: none"> <li>• Battery charge is low (below 10.5V), please change battery to ensure safe operation. When the light senses a low battery it will flash for 0.5 seconds every 10 seconds.</li> </ul>



**Notes**



## Sealite LED Light Warranty V2.1

### Activating the Warranty

Upon purchase, the Sealite Pty Ltd warranty must be activated for recognition of future claims. To do this you have two (2) options:

1. **Postal Registration** - please complete the Sealite Warranty Registration Card and return to Sealite within 30 days of your purchase.
2. **Online Registration** - please complete the Online Registration Form at; [www.sealite.com](http://www.sealite.com)

***Sealite Pty Ltd will repair or replace your LED light in the event of electronic failure for a period of up to three years from the date of purchase.***

***The unit must be returned to Sealite freight prepaid.***

### Warranty Terms

1. Sealite Pty Ltd warrants that any Sealite marine products fitted with telemetry equipment including but not limited to AIS, GSM, GPS or RF ("Telemetry Products") will be free from defective materials and workmanship under normal and intended use, subject to the conditions hereinafter set forth, for a period of twelve (12) months from the date of purchase by the original purchaser.
2. Sealite Pty Ltd warrants that any BargeSafe™ Series of LED barge light products ("BargeSafe™ Products") will be free from defective materials and workmanship under normal and intended use, subject to the conditions hereinafter set forth, for a period of twelve (12) months from the date of purchase by the original purchaser.
3. Sealite Pty Ltd warrants that any LED area lighting products ("Area Lighting Products") but not including sign lighting products will be free from defective materials and workmanship under normal and intended use, subject to the conditions hereinafter set forth, for a period of twelve (12) months from the date of purchase by the original purchaser.
4. Sealite Pty Ltd warrants that any LED sign lighting products ("Sign Lighting Products") will be free from defective materials and workmanship under normal and intended use, subject to the conditions hereinafter set forth, for a period of three (3) years from the date of purchase by the original purchaser.
5. Sealite Pty Ltd warrants that any Sealite marine lighting products other than the Telemetry Products, BargeSafe™ Products, and Area Lighting Products ("Sealite Products") will be free from defective materials and workmanship under normal and intended use, subject to the conditions hereinafter set forth, for a period of three (3) years from the date of purchase by the original purchaser.
6. Sealite Pty Ltd will repair or replace, at Sealite's sole discretion, any Telemetry Products, BargeSafe™ Products, Area Lighting Products or Sealite Products found to be defective in material and workmanship in the relevant warranty period so long as the Warranty Conditions (set out below) are satisfied.
7. If any Telemetry Products, BargeSafe™ Products, Area Lighting Products or Sealite Products are fitted with a rechargeable battery, Sealite Pty Ltd warrants the battery will be free from defect for a period of one (1) year when used within original manufacturer's specifications and instructions.

### Warranty Conditions

This Warranty is subject to the following conditions and limitations;

1. The warranty is applicable to lanterns manufactured from 1/1/2009.
2. The warranty is void and inapplicable if:
  - a. the product has been used or handled other than in accordance with the instructions in the owner's manual and any other information or instructions provided to the customer by Sealite;
  - b. the product has been deliberately abused, or misused, damaged by accident or neglect or in being transported; or
  - c. the defect is due to the product being repaired or tampered with by anyone other than Sealite or authorised Sealite repair personnel.

3. The customer must give Sealite Pty Ltd notice of any defect with the product within 30 days of the customer becoming aware of the defect.
4. Rechargeable batteries have a limited number of charge cycles and may eventually need to be replaced. Typical battery replacement period is 3-4 years. Long term exposure to high temperatures will shorten the battery life. Batteries used or stored in a manner inconsistent with the manufacturer's specifications and instructions shall not be covered by this warranty.
5. No modifications to the original specifications determined by Sealite shall be made without written approval of Sealite Pty Ltd.
6. Sealite lights can be fitted with 3rd party power supplies and accessories but are covered by the 3rd party warranty terms and conditions.
7. The product must be packed and returned to Sealite Pty Ltd by the customer at his or her sole expense. Sealite Pty Ltd will pay return freight of its choice. A returned product must be accompanied by a written description of the defect and a photocopy of the original purchase receipt. This receipt must clearly list model and serial number, the date of purchase, the name and address of the purchaser and authorised dealer and the price paid by the purchaser. On receipt of the product, Sealite Pty Ltd will assess the product and advise the customer as to whether the claimed defect is covered by this warranty.
8. Sealite Pty Ltd reserves the right to modify the design of any product without obligation to purchasers of previously manufactured products and to change the prices or specifications of any product without notice or obligation to any person.
9. Input voltage shall not exceed those recommended for the product.
10. Warranty does not cover damage caused by the incorrect replacement of battery in solar lantern models.
11. This warranty does not cover any damage or defect caused to any product as a result of water flooding or any other acts of nature.
12. There are no representations or warranties of any kind by Sealite or any other person who is an agent, employee, or other representative or affiliate of Sealite, express or implied, with respect to condition of performance of any product, their merchantability, or fitness for a particular purpose, or with respect to any other matter relating to any products.

### **Limitation of Liability**

To the extent permitted by section 68A of the Trade Practices Act 1974 (Cth), the liability of Sealite Pty Ltd under this Warranty will be, at the option of Sealite Pty Ltd, limited to either the replacement or repair of any defective product covered by this Warranty. Sealite will not be liable to Buyer for consequential damages resulting from any defect or deficiencies.

### **Limited to Original Purchaser**

This Warranty is for the sole benefit of the original purchaser of the covered product and shall not extend to any subsequent purchaser of the product.

### **Miscellaneous**

Apart from the specific warranties provided under this warranty, all other express or implied warranties relating to the above product is hereby excluded to the fullest extent allowable under law. The warranty does not extend to any lost profits, loss of good will or any indirect, incidental or consequential costs or damages or losses incurred by the purchaser as a result of any defect with the covered product.

### **Warrantor**

Sealite Pty Ltd has authorised distribution in many countries of the world. In each country, the authorised importing distributor has accepted the responsibility for warranty of products sold by distributor. Warranty service should normally be obtained from the importing distributor from whom you purchased your product. In the event of service required beyond the capability of the importer, Sealite Pty Ltd will fulfil the conditions of the warranty. Such product must be returned at the owner's expense to the Sealite Pty Ltd factory, together with a photocopy of the bill of sale for that product, a detailed description of the problem, and any information necessary for return shipment.

**Other Sealite Products Available**



**Marine Lanterns**  
**(1-12nm+)**



**Monitoring**  
**& Control Systems**



**Bridge & Barge Lights**



**Marine Buoys**  
**(up to 3mt in diameter)**

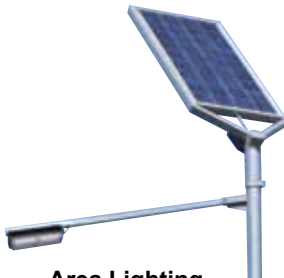

**Area Lighting**



**Mooring Systems**  
**& Accessories**



**Head Office**  
Sealite Pty Ltd  
11 Industrial Drive  
Somerville, Vic 3912  
Australia  
Tel: +61 3 5977 6128  
Fax: +61 3 5977 6124  
Email: info@sealite.com  
Internet: www.sealite.com

