



Installation Instructions



Easy to assemble and with no maintenance required, ThruFlow™ is designed to be the finished walkway for a dock, or any outdoor flooring structure.

ThruFlow's™ design minimizes storm damage from wind and surge effects, as well as helps to protect marine life by allowing light to penetrate waterways.

PRODUCT DATA

Material	Reinforced Polypropylene (ThruFlow™ is lightweight in comparison to other building materials)
Size	1' x 3', 1' x 4' and 1' x 5'
Load	Great Load Bearing Capability
Colours	Light Grey, Cream and Maple
Ultraviolet Protection	Full UV Protection
Light Availability	Allows Light to Penetrate
Surface	360 Degree Knurled Surface Offers Superior Grip
ThruFlow™ Warranty	Limited Warranty
(For the most up to date technical specifications including load, coefficient of friction, and coefficient of linear thermal expansion visit www.thruflow.com)	

INSTALLATION

It is important that the configuration of the supporting members be designed to ensure independent structural integrity prior to installing ThruFlow™. Specifications for ThruFlow™ are available upon request.

CODES and STANDARDS: Always conform to your local building codes and the requirements of all authorities having jurisdiction.

SAFETY: Protective safety equipment is always recommended, e.g. eyewear, safety boots.

FASTENERS: We recommend high quality screws, such as #10 or #12, pan head stainless steel screws to take advantage of ThruFlow's™ longevity. Pre-drilling is not required, as the holes are molded in with a countersink for your convenience; screws should be clear through the panel and fastened into the structure of your structural frame. Remember not to tighten the screws down to allow for expansion or contraction.

GAPPING INSTRUCTIONS: While ThruFlow™ Interlocking Panels will not shrink or swell due to changes in moisture, changes in temperature will cause slight expansion/contraction. Therefore, gapping is required both side-to-side and at the panel ends to allow for thermal expansion/contraction. Rules of Thumb: ThruFlow™ Interlocking Panels should be allowed to grow a minimum of 1/16" in total length (1/32" each end) and 1/32" in total width (1/64" per side) for every 30°F of difference between installation temperature and the hottest temperature expected. In cold climate regions, gapping due to contraction of plastic will occur during colder temperatures in the exact reverse proportions of those described above. Coefficient of Linear Thermal Expansion data for the panels is available at www.thruflow.com on the specifications page.

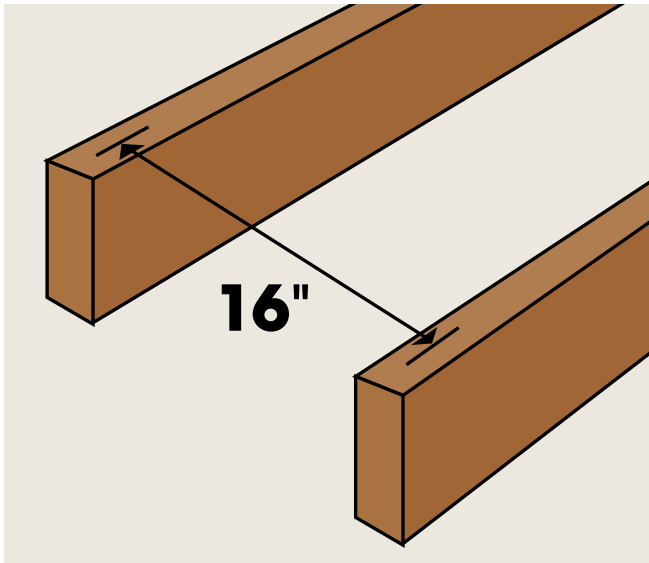

STEP 1

Substructure to be constructed with cross-members equally spaced on 18" centres (3' planks), 16" centres (4' planks) and 15" centres (5' planks).

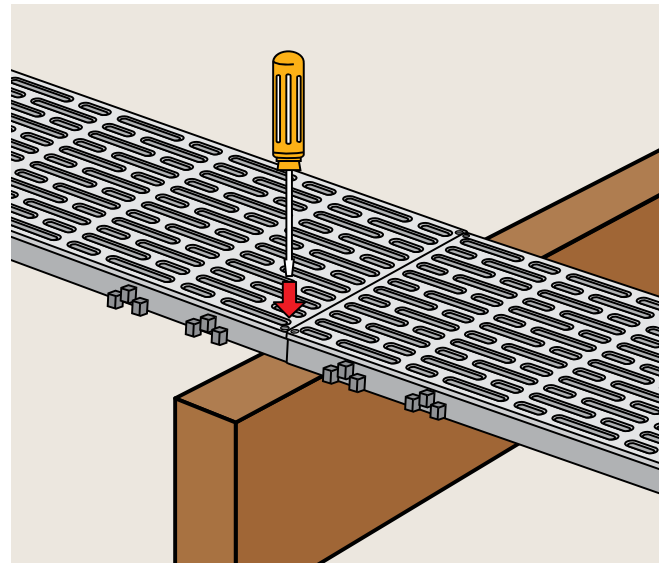

STEP 2

Lay the first ThruFlow™ on the substructure and fasten using a pan head screw. Hand tighten each screw.

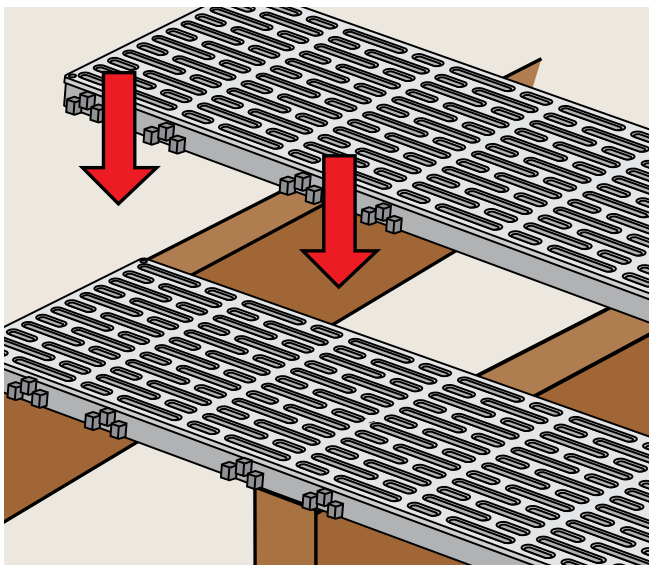

STEP 3

Using the interlocking system, lay the next ThruFlow™ panel and repeat the fastening process.

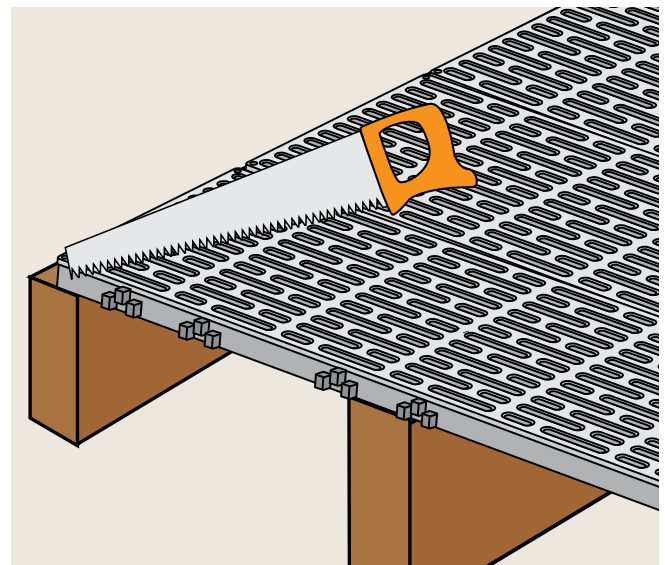

STEP 4

To finish the installation, remove the last row of interlocking tabs, using any traditional hand or electric saw.