

# SLB700CG USCG Regulatory Style

## 700mm dia. Marker Buoy

Sealite have a range of mooring chains & accessories - ask your representative today how we can supply your complete mooring solution

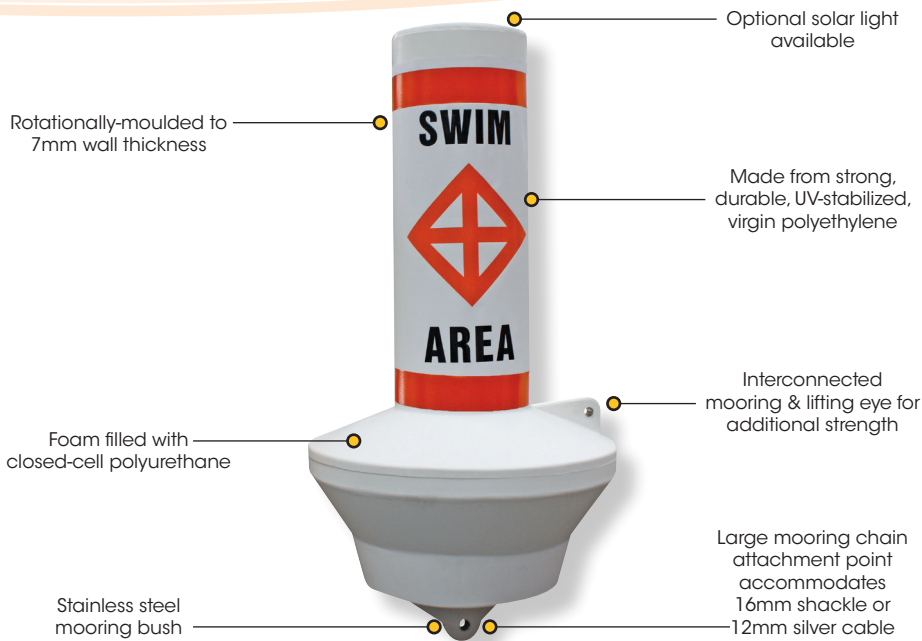

### The Sealite Advantage

- High visibility orange, red, green, white or yellow as per IALA recommendations
- Range of mooring equipment & chain available
- Excellent buoyancy & stability
- Replaceable vinyl buoy wraps or mould-in graphics to suit customer requirements

### The SLB700 USCG Regulatory Style buoy is ideal for regulatory signs and for marking hazards, mooring fields, and channels in lakes, rivers, and coastal harbors.

This model is extremely long-lasting, and is moulded in strong, durable, UV-stabilized polyethylene. A large mooring chain attachment point accommodates a 16mm shackle or 12mm silver rope.

The SLB700 Regulatory Style Buoy incorporates an interconnected mooring and lifting eye for additional strength and flexibility in installation. The top section has 3 threaded studs, moulded into the buoy to enable easy mounting of either the SL15, SL60 or SL70 1-3nm+ solar lights.

Vinyl buoy wraps constructed of heavy, 10 oz. vinyl, have standard regulatory symbols and wording and are highly customizable. Attachment is straightforward, with self-sealing rivets (standard) or Velcro® for temporary or emergency applications. Sealite also provide the option of customised graphics which are permanently moulded into the product at the time of manufacture and will hold up under the most extreme environments and never peel off or fade over time.

Optional Mould-in Graphics Available



Environmentally Friendly & Recyclable

Sealite buoy products are made from recyclable materials. As a service to customers, individual components and products at the end of their service life may be returned to Sealite for recycling.

### Available Configurations

- Regulatory buoy. Orange/white
- Hazard buoy. Orange
- Channel markers. Red or green
- Special purpose marks. Yellow



# SLB700CG USCG Regulatory Style 700mm dia. Marker Buoy

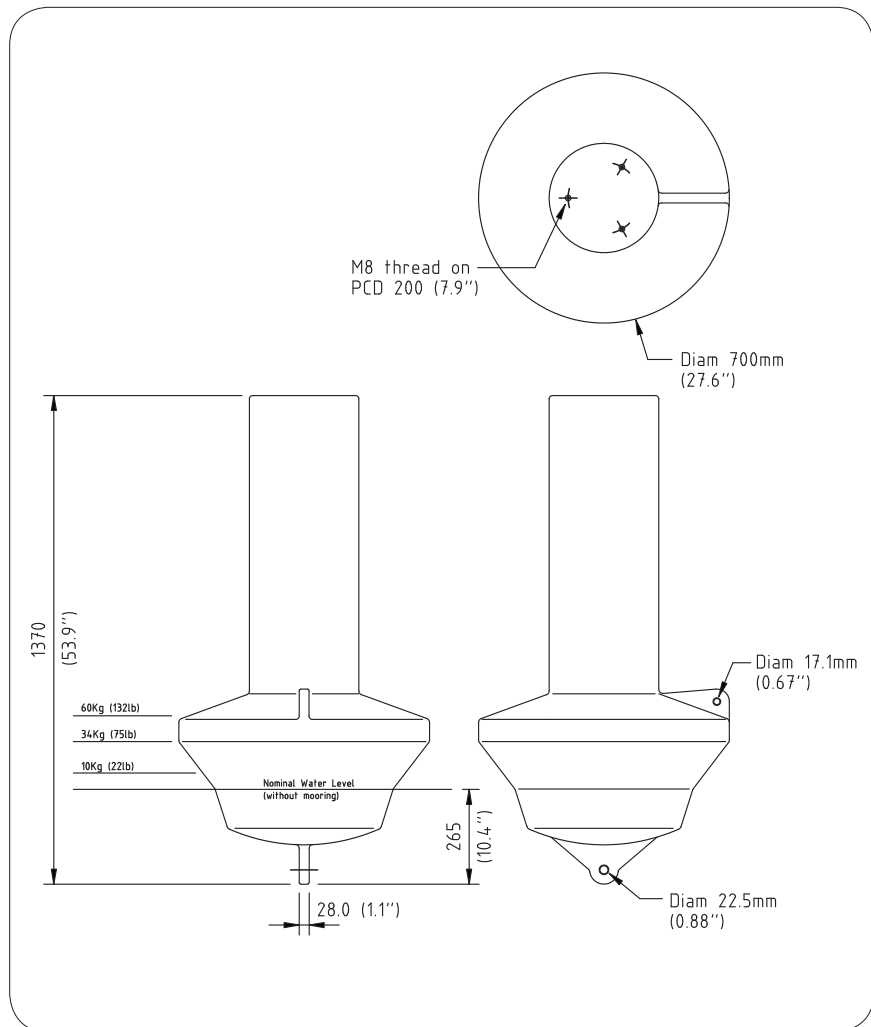

## SPECIFICATIONS •

### General Characteristics

Available Colours	Orange, Red, Green, White, Yellow as per IALA Recommendations
Focal Plane Height (mm/inches)	1155 / 45 <sup>1</sup> / <sub>2</sub>
Total Float Volume (lts/US gallon)	197 / 52
Nominal Freeboard (mm/inches)	408 / 16
Nominal Draft (mm/inches)	223 / 8 <sup>3</sup> / <sub>4</sub>
Reserve Buoyancy (kgs/lbs)	60 / 132
Maximum Mooring Load (kgs/lbs)	60 / 132
Draft, Maximum (mm/inches)	470 / 18 <sup>1</sup> / <sub>2</sub>
Freeboard, Minimum (mm/inches)	160 / 6 <sup>1</sup> / <sub>4</sub>
Submergence (kg/cm, lb/inches)	3.8 / 21.6

### Physical Characteristics

Material	Rotationally-moulded UV-stabilized virgin polyethylene,
Wall Thickness (mm/inches)	7 / <sup>1</sup> / <sub>4</sub>
Ballast (kg/lbs)	20 / 44 internal concrete
Filling	Closed-cell polyurethane foam
Height (mm/inches)	1370 / 53 <sup>7</sup> / <sub>8</sub>
Width (mm/inches)	700 / 27 <sup>1</sup> / <sub>2</sub>
Mass (kg/lbs)	38 / 84
Product Life Expectancy	Up to 12 years

### Certifications

Quality Assurance ISO9001:2008

### Intellectual Property

Trademarks

SEALITE® is a registered trademark of Sealite Ply Ltd  
1 year

### Warranty \*

### Lantern Options

Sealite SL15, SL60 or SL70 lantern

### Options Available

- Mould-in graphics
- Vinyl wraps



\* Specifications subject to change or variation without notice  
\* Subject to standard terms and conditions